

Assembly instruction

Applicable product model :

JK049-2II/-3II

M8x55

M8x70

M6x30

Ø8

m8



A=2

B=4

C=4

D=10

E=4

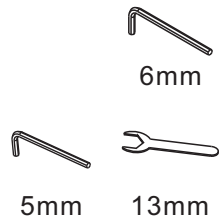
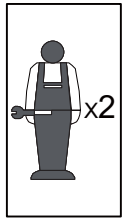
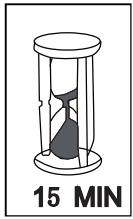

(1)=2



(2)=2

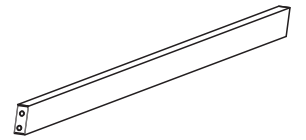

(3)=1

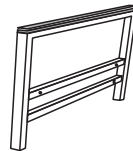
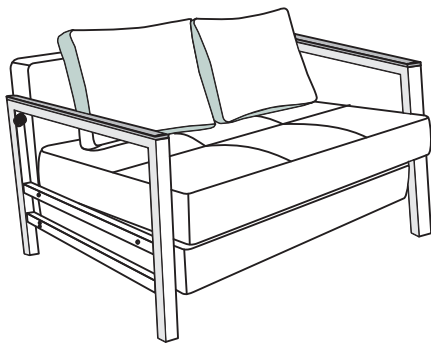

(4)=2

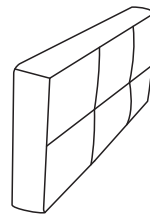

(5)=1

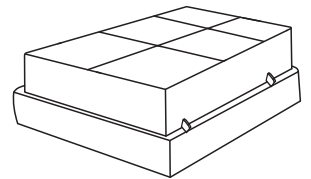

(6)=1

step1

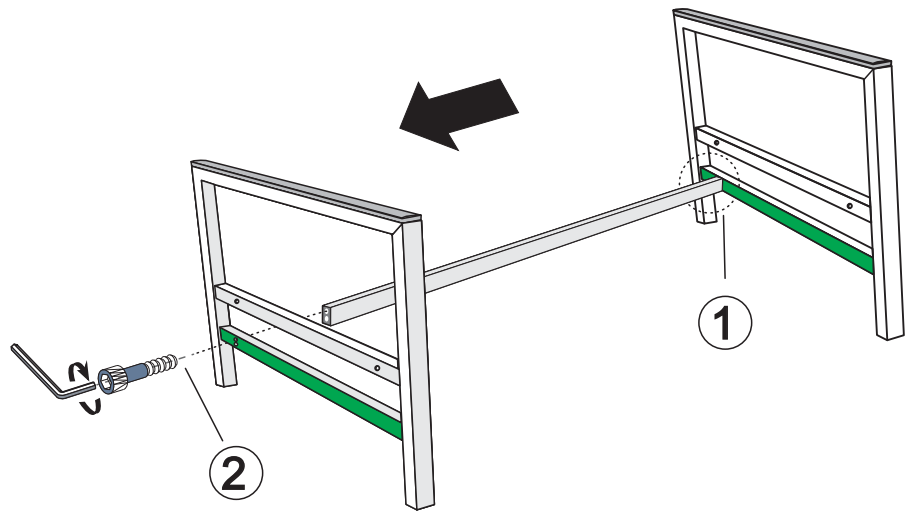

① ②

②

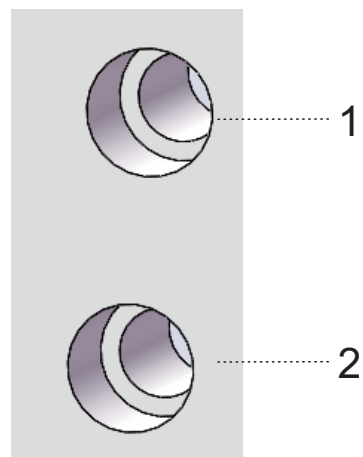
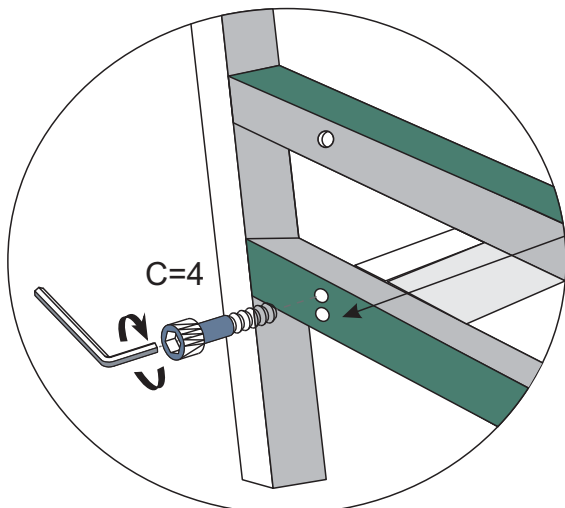

step2

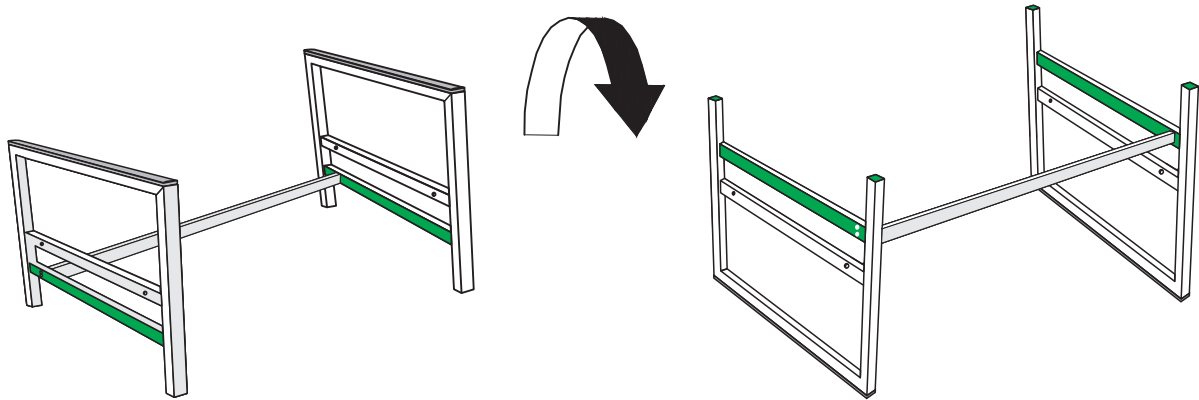

step3

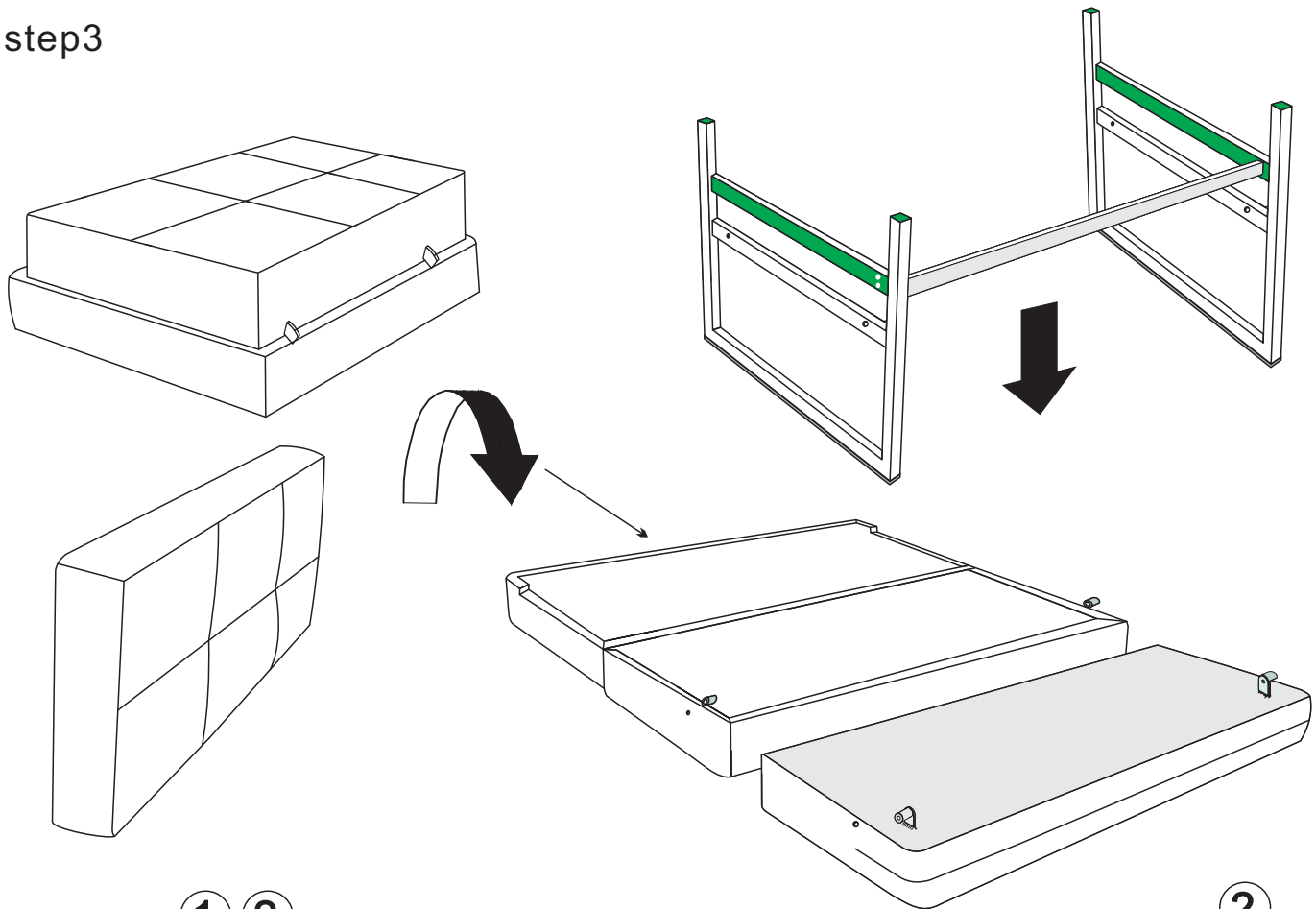

① ②

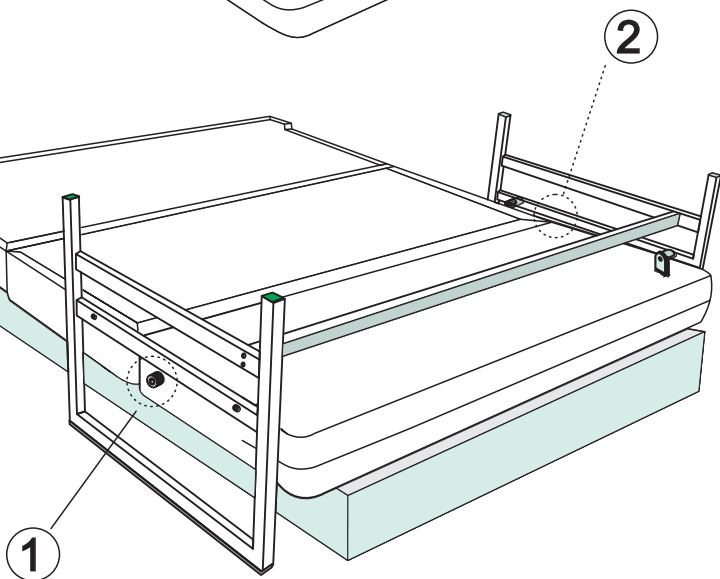
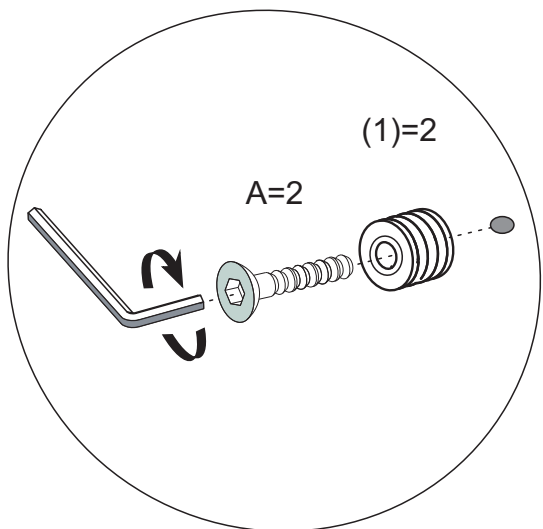

step4

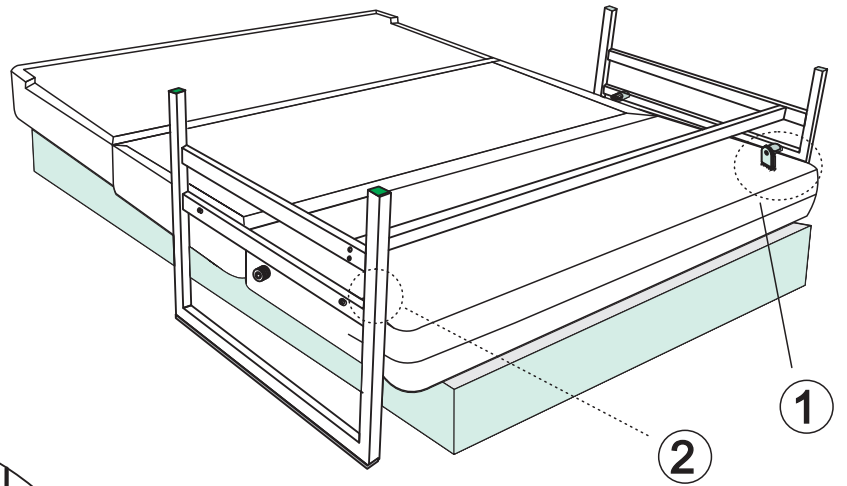

1 2

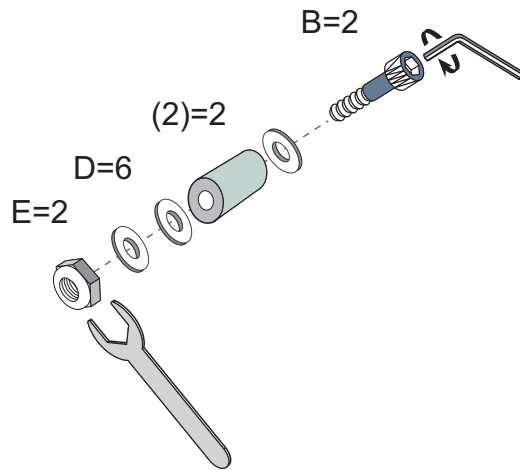
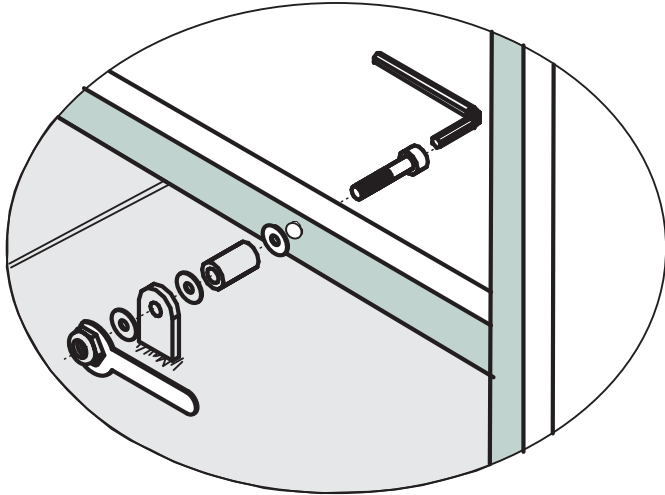

step5

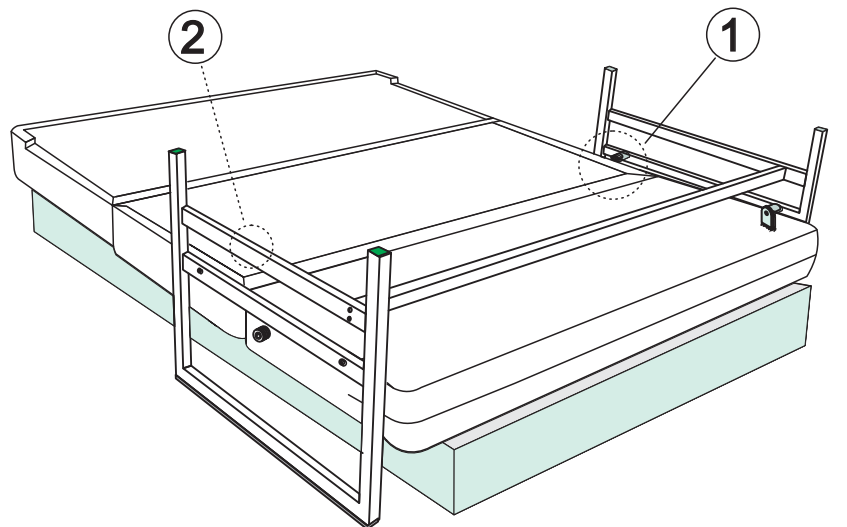

1 2

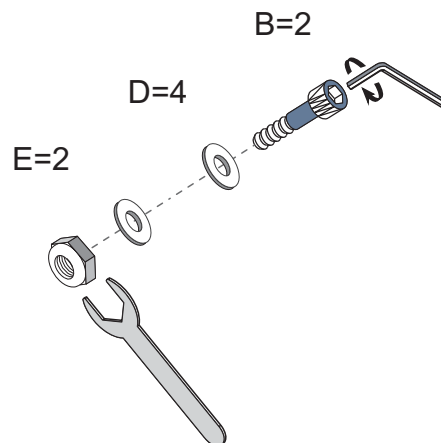
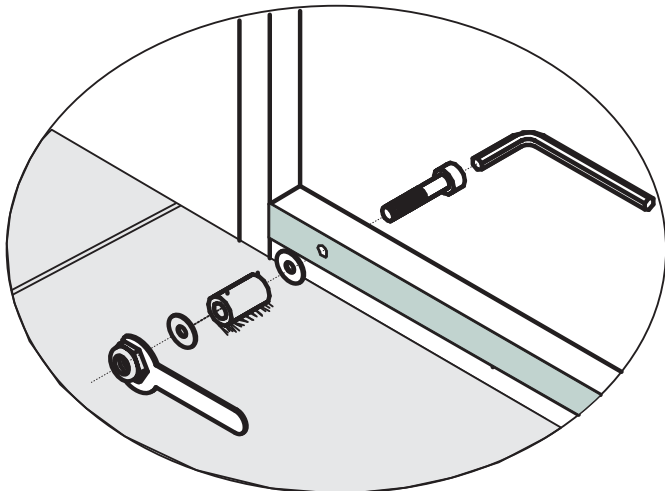

Assembly instruction

Applicable product model :

JK049-2II/-3II

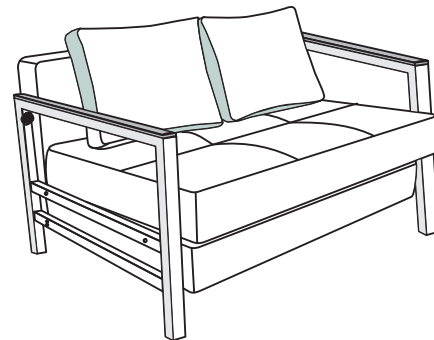

1

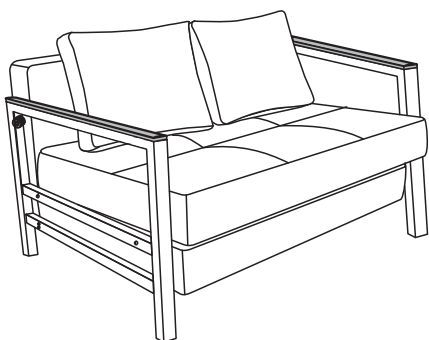

2

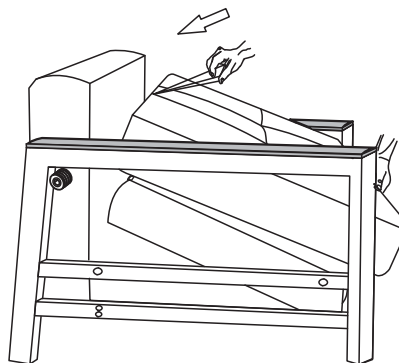

3

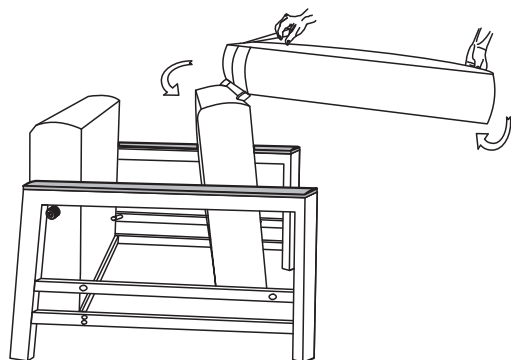

4

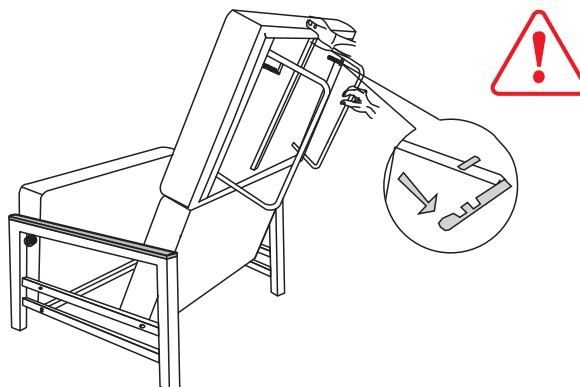

5

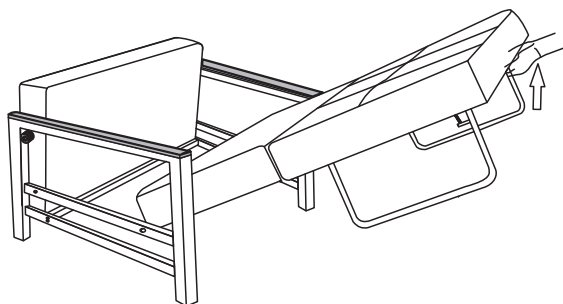

6

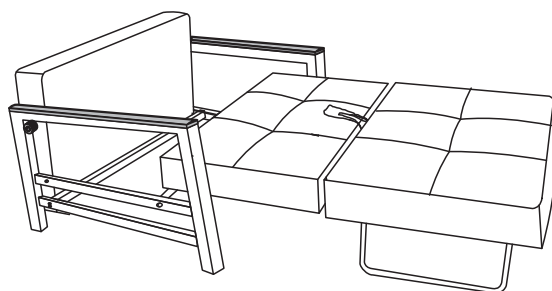

7

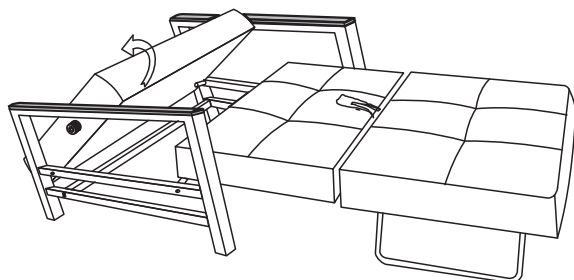

8

